

DOUBLE TOILET ROLL HOLDER WP149



240 x 110 x 90 mm
for 2 toilet rolls

- Double toilet roll holder in robust, germ-reducing and easy-care stainless steel (AISI 304).
- All-stainless steel construction, visible surfaces satin finished and brushed.
Further available surfaces: see below.
- Designed for two standard toilet rolls with dimensions:
Outer diameter max. 125 mm
Width max. 100 mm
Core diameter min. 38 mm
- Accessible for refilling by unlocking the center axis.
- Keyed alike cylinder lock in corrosion-resistant zinc die-casting.
- Wear parts can be replaced as modules.
- Mounting: With two screws through fixing holes in the back wall.
- Delivery includes fixing material.
- Weight, including single package: 0.9 kg



Suggested text for specifications:

Double toilet roll holder in stainless steel (AISI 304) for surface mounting. All-stainless steel construction, visible surfaces satin finished and brushed. Designed for two standard toilet rolls. Accessible for refilling by unlocking the center axis. Keyed alike cylinder lock in corrosion-resistant zinc die-casting. Delivery includes fixing material.

Dimensions: 240 x 110 x 90 mm

Article No. WP149

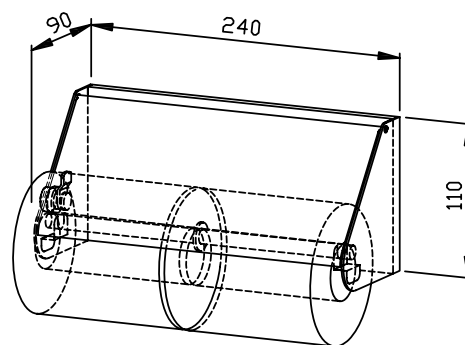

Available surfaces	ID No.
satin finished (standard)	764 210
highly polished	732 210
(coloured) plastic powder-coating	730 210

Ernst Wagner GmbH & Co. KG

Ernst-Abbe-Straße 21 · D-72770 Reutlingen · Tel.: +49712151539-0 · Fax: -20
info@wagner-ewar.de · www.wagner-ewar.de

WAGNER
E W A R